



## OPERATING MANUAL

### Gilson Silent Sifter SS-21



Rev: 02/27/2013

## SAFETY INSTRUCTIONS

Whether you are the owner, employer, operator, or maintenance person for this machine, safety is your responsibility. You are responsible for operating and maintaining this equipment in compliance with these instructions and for using common sense. Review and completely understand the operating and safety instructions before using this machine.

### WARNING!

**This machine operates on electric current. Improper operation could result in electric shock, electrocution, or an explosion!**

1. **ALWAYS** ensure the motor and other electrical components are properly configured for your intended use and available power source. The Gilson SS-20 Rotary Sifter comes with a 1/3hp motor wired for 115V/60Hz. Motors are **NOT** explosion-proof.
2. **ALWAYS** check electrical wiring for loose connections and for pinched or frayed wiring.
3. **ALWAYS** use the factory-installed three-pronged plug. Connect the machine to a properly wired and grounded three-pronged receptacle. Make sure the cord is located where no one will trip or get tangled in it.
4. **ALWAYS** disconnect and lock out power supply before performing maintenance and repairs.

### WARNING!

**WARNING:** **DO NOT** operate the machine without having all covers and cabinet in place.

**WARNING:** Stop the machine immediately if excessive noise, vibration or machine movement occurs.

**WARNING:** The electric motor on this machine has internal thermal protection. If the motor shuts off from overload, the machine may restart by itself after cooling off, unless the machine is unplugged during cool-down.

**WARNING:** **ALWAYS** unplug or disconnect machine from the power source when the unit is not in operation.

**WARNING:** Keep all parts of your body away from moving parts of the machine while it is operating.

**WARNING:** **ALWAYS** wear safety glasses and recommended hearing protection when operating, maintaining, or repairing this machine.

# Table of Contents

	<b>Page</b>
<b>Safety Instructions</b>	<b>2</b>
<b>Table of Contents</b>	<b>3</b>
<b>1.0 Introduction</b>	<b>4</b>
<b>2.0 Unpacking &amp; Set-Up</b>	<b>4</b>
<b>3.0 Operating Instructions &amp; Components</b>	<b>4</b>
3.1 Test Specimen & Sieve Stack Assembly	4
3.2 Timer Set-Up & Operation	5
3.3 SS-21 Components	6
<b>4.0 Maintenance</b>	<b>7</b>
<b>5.0 Troubleshooting</b>	<b>7</b>
<b>6.0 Specifications</b>	<b>7</b>
<b>7.0 Parts Diagrams &amp; Electrical Schematic</b>	<b>8</b>
7.1 SS-21 External Parts Diagram	8
7.2 SS-21 Internal Parts Diagram	9
7.3 SS-21 Electrical Schematic	10
<b>8.0 Parts List</b>	<b>11</b>
8.1 SS-21 Parts List	11
<b>9.0 Additional Information</b>	<b>12</b>
9.1 Gilson Test Sieves	12
9.2 Test Sieve & Screen Tray Verification & Services	13
9.3 8in Diameter ASTM Test Sieves	15
9.4 12in Diameter ASTM Test Sieves	16
9.5 ISO 200/300mm Test Sieves	17
9.6 Accessories	18

## 1.0 INTRODUCTION:

### GILSON SILENT SIFTER

- Built by Gilson, backed by Gilson.
- Accurate results.
- Simple and efficient.
- Ergonomic test positioning knob.

Gilson has revamped the classic rotary sifter design and added our own innovations. This proven sieving method preferred by many DOT's is now available with Gilson-guaranteed quality and reliability.

Gilson's progressive design carries forward the best features of traditional rotary sifters and adds upgrades drawn from our expertise in particle separation technology. Faster conversion between sieve sizes, easier set up, and quieter operation all reflect the time devoted to improved design and materials.

The totally enclosed design allows safe, dust-free operation. The cabinet is oriented at an angle, and the sieve stack is simply placed inside, resting against the rollers; no clamping is required. An ergonomic knob allows easy rotation of the cabinet between the loading and testing positions. A drive roller system continuously rotates the sieve stack with particle separation assisted by tapping against the stack. The digital countdown timer with large LED display precisely times operation.

## 2.0 UNPACKING & SET-UP:

The SS-21 weighs approximately 215lb. Use appropriate equipment and manpower to uncrate and assemble the Gilson Silent Sifter. Wear safety glasses and work gloves.

The SS-21 Gilson Silent Sifter is shipped with the Steel Support Stand detached. The Sifter Cabinet must be installed on the Support Stand to operate properly. **DO NOT** attempt to operate the Sifter until properly assembled. See Figure 1 for components.

1. Remove the two halves of the Steel Support Stand from the box. Each half has a Frame Cross Rail partially bolted to the bottom rail.
2. Set the Support Stand halves parallel to each other on a sturdy surface. Swing each cross rail out 90° and connect to the opposite bottom rail, securing with the bolts and nuts supplied. Tighten all connections securely.
3. Remove the top half of the pivot post mounts from the Floor Stand and set aside.

4. Use two people to lift the Sifter Cabinet and carefully set it vertically on the frame so that both Pivot Posts rest in the "saddle" of the pivot post mounts. Replace the top half of the mounts and secure the bolts.
5. Check that all connections are secure and that the Sifter rotates properly 45° back from vertical to its testing position against the Cabinet Rotation Stops.
6. Carefully read and understand the rest of these instructions prior to operating the SS-21.
7. For any questions or issues, please contact Gilson Technical Support at **800.444.1508**, or email **techsupport@gilsonco.com**.

**NOTE:** The Gilson SS-21 Silent Sifter comes with a 1/3hp motor wired for 115V/60Hz, and must be connected to a properly grounded, dedicated outlet of minimum 15 amp capacity. The motor is **NOT** explosion-proof.

## 3.0 OPERATING INSTRUCTIONS:

**NOTE:** Please read and understand all safety and operating instructions for the Gilson SS-21 Silent Sifter before putting it into service.

### 3.1 Test Specimen & Sieve Stack Assembly

The Gilson Silent Sifter efficiently separates most free-flowing materials with particle sizes from No.4—No.200 (4.75mm—75µm). Performance on extended size ranges can be determined by experimentation. The test specimen should be large enough to be representative, without overloading any individual sieve. Maximum loading for individual sieves No.4 and finer should be no more than 200g for 8in sieves and 450g for 12in sieves, for materials with specific gravities similar to mineral aggregates. Sieves coarser than No.4 should be limited to about one particle of material for each available opening.

**NOTE:** Overloading on one or more sieves may result in incomplete separation, inaccurate results, or damage to the sieve cloth. Large samples should be tested as two or more batches, combining the results for final calculations.

Determine what size test sieves will be used, and adjust the Silent Sifter to the proper settings. There are two openings approximately 2in apart in the center of the cabinet bottom (see Figure 1). Insert the post of the sieve turntable into the proper opening; the opening toward the front is for 12in or 300mm diameter sieves, and the one toward the back is for 8in or 200mm diameter sieves. Set the sieve size selector knob on the front control panel to “12” or “8”. This adjusts the springs controlling the tapping hammers for the best tapping force.

In addition to the test sieves selected for the test, the sieve stack must include the appropriate receiving pan and a sieve cover. Assemble the sieve stack with the pan and finest sieves on the bottom, progressing to the coarsest sieves on top. Deposit the prepared test specimen onto the top sieve, and put the cover on.

Open the cabinet door all the way. Special heavy-duty hinges allow the door to swing 170° for complete and easy access to the interior. Carefully place the entire sieve stack with sample on the sieve turntable in the Silent Sifter, resting the stack against the rubber-covered rollers in the back of the cabinet. Use the ergonomic knob on the side of the case to tilt the cabinet back against the cabinet rotation stops to its operating angle of approximately 45°. Taller operators may find it more convenient to load the sieve stack with the cabinet already tilted back. Close the cabinet door completely.

**NOTE:** Before starting a test cycle, the Silent Sifter cabinet must be tilted back against the rotation stops. Failure to do this may result in incomplete separation or loss of the test specimen.

**NOTE:** The Door Safety Switch prevents operation of the Sifter and Timer until the cabinet door is completely closed. Disabling this switch makes operation of the Sifter dangerous and voids the warranty.

### 3.2 Timer Set-Up & Operation

This unit is equipped with an easy-to-operate Gilson interval count-down timer. The timer has a large 0.6in LED display and will operate in four different modes. It is powered by line voltage and will work on power supplies from 100—265 VAC, 50/60Hz, with up to 20 amps Inductive or Resistive current.

**NOTE:** The Silent Sifter motor controlled by the timer is restricted to operating on a limited electrical supply range. Check carefully to insure compatibility with your electrical supply.

Current timer mode is indicated by the four red LED's on the timer face:

- A = MMSS (99min:59sec x 1 second)
- B = HHMM (99hr:59min x 1 minute)
- C = SSSS (9999sec x 1 second)
- D = MMMM (9999min x 1 minute)

(H is for hours, M for minutes, and S for seconds.) To adjust the timer mode, press and hold both <UP> and <DOWN> keys at the same time until the display shows the mode. Once the mode letters are displayed, press <UP> or <DOWN> to change modes. Press <START/STOP> to accept new mode.

The time required to complete a test will vary depending upon the physical characteristics of the test material. Most separations will be complete in ten minutes or less. It may require experimentation to determine the optimum test time for a particular material.

To set the run time, press either <UP> or <DOWN>. The first digit on the right hand side will flash in half-second intervals. Press either arrow key to adjust to the desired value. To enter the displayed digit and move to the next, press <START/STOP>. Once the last digit on the left is entered, the timer is ready to start.

Insure the cabinet is rotated back to its operating angle of 45°, then Press <START/STOP> to initiate the current run program. Once running, pressing <START/STOP> again will pause the timer with the current amount of time remaining on screen. When allowed to time-out, the timer beeps and displays DONE. Press any key to reset the timer and prepare it for the next cycle. Setting and Mode values are saved automatically.

**NOTE:** Opening the cabinet door in the middle of a test cycle shuts off all power to the timer and motor. When the door is closed again, the timer will be reset to the originally programmed time interval.

When the test cycle is complete, open the cabinet door and remove the sieve stack for weight determinations.

### 3.3 SS-21 Components

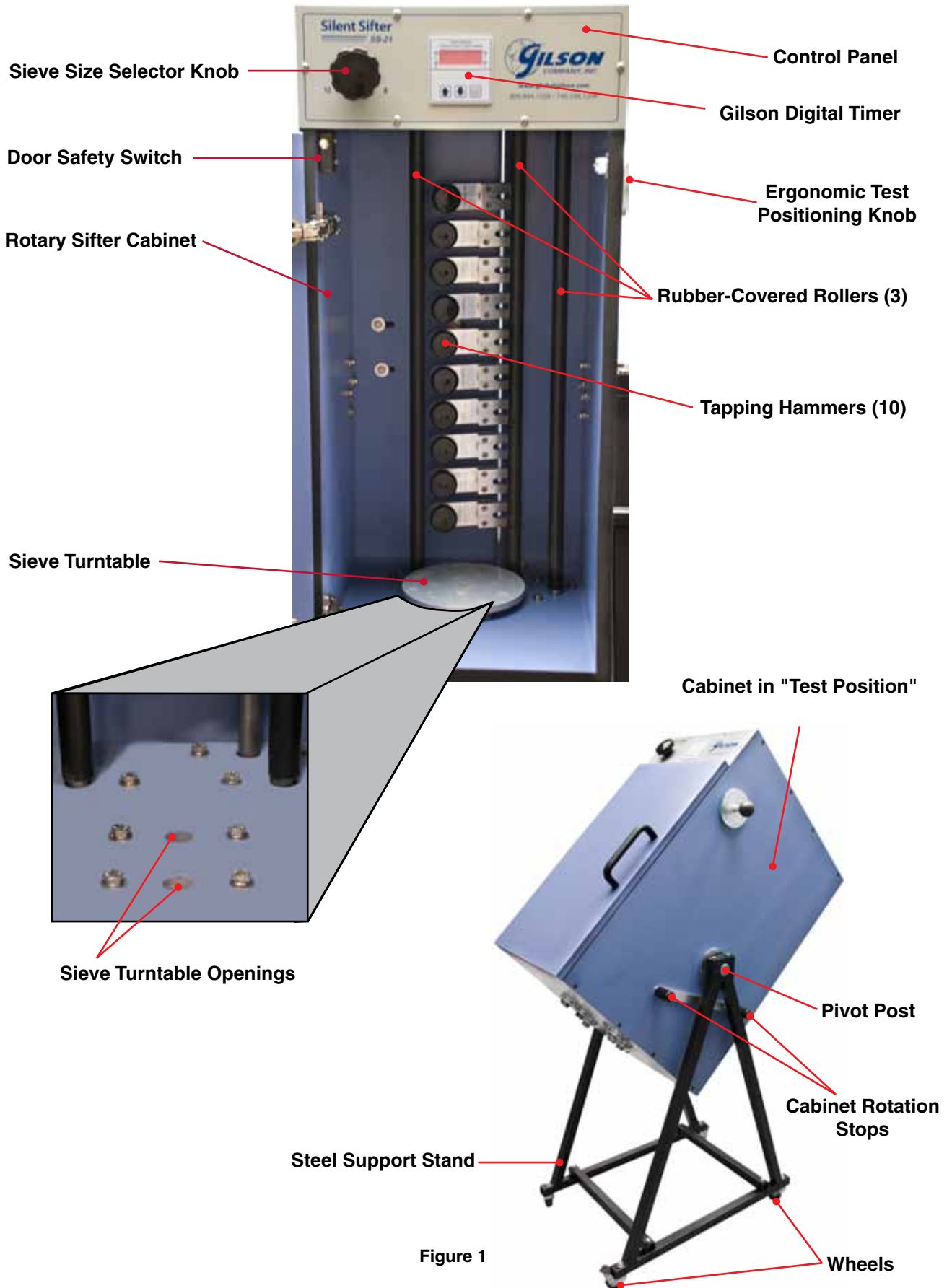

Figure 1

## 4.0 MAINTENANCE:

Before performing maintenance or repairs on the sieve shaker, **ALWAYS** read and understand the safety, operating, and maintenance instructions.

## 5.0 TROUBLESHOOTING:

GILSON SILENT SIFTER TROUBLESHOOTING		
Symptoms	Possible Causes	Solutions
No power to display, machine will not operate.	Power disconnected.	Reconnect to power supply.
	Door not closed completely.	Close door completely.
	Faulty door safety switch.	Check connections and/or replace door safety switch.
Display is lit, but motor does not run.	Faulty connections/wiring.	Trace circuits with electrical meter.
	Faulty timer.	Diagnose timer output/connections.
	Faulty motor.	Replace motor.
Display is lit, motor runs, but machine does not operate properly.	Loose or broken drive belt.	Adjust tension or replace belt.
	Pulley(s) loose on shaft(s).	Tighten set screws on shaft bearings.
	Turntable installed in wrong opening.	Install turntable in correct opening.
	Sieve size selection knob not set correctly.	Set selection knob to correct size.
Excessive noise and vibration.	Sieve stack not seated properly.	Seat sieve stack properly.
	Turntable installed in wrong opening.	Install turntable in correct opening.
	Improperly adjusted or broken drive components.	Check belts, pulleys, bearings and rods. Adjust or replace as required.
	Sieve size selection knob not set correctly.	Set selection knob to correct size.
Excessive loss of specimen fines during testing.	Damaged or deformed sieve frames or flanges.	Replace damaged or deformed sieves.
	Sieves not seated properly.	Seat sieves properly.
Inconsistent or unexpected test results.	Damaged/out of specification sieve cloth.	Replace sieve.
	Blinded sieve mesh.	Clean sieve.
	Improper tapper operation.	Adjust or repair tappers.
	Insufficient test time.	Increase test time.

Contact Gilson Technical Support for assistance in diagnosis and repair of problems with the Gilson Silent Sifter.  
**E-mail: [techsupport@gilsonco.com](mailto:techsupport@gilsonco.com) or Call: 800.444.1508**

## 6.0 SPECIFICATIONS:

<b>Particle Size Range:</b>	No.4—No.200 (4.75mm—75µm) Nominal (Extended ranges possible, depending on material type).
<b>Sieve Capacity:</b>	8in or 200mm Diameter 10 Full-Height 20 Half-Height 12in or 300mm 6 Full-Height 10 Intermediate-Height 13 Half-Height
<b>Controller:</b>	Gilson Count-Down Timer, 99min:59sec x 1sec. (Maximum 99hr:59min x 1min).
<b>Motor:</b>	1/3hp, 1725rpm, Continuous Duty
<b>Power Requirements:</b>	115V/60Hz AC, 10 amps
<b>Dimensions:</b>	19x24x58in (483x610x1473mm), WxDxH
<b>Weight:</b>	195lb (88kg)
<b>Ship Weight:</b>	215lb (98kg)

## 7.0 PARTS DIAGRAMS & ELECTRICAL SCHEMATIC:

### 7.1 SS-21 External Parts Diagram

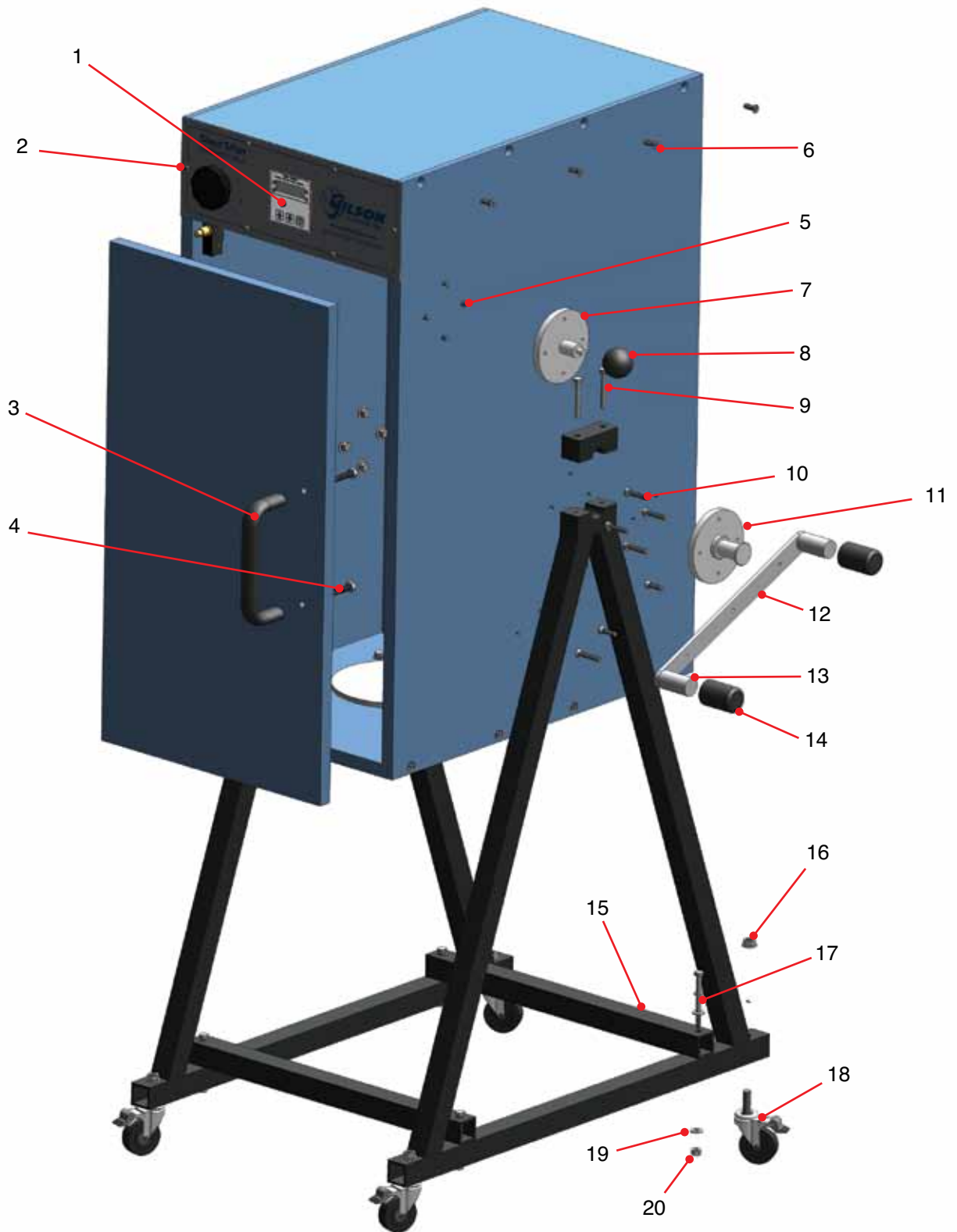

SS-21 External Parts Diagram

### 7.2 SS-21 Internal Parts Diagram

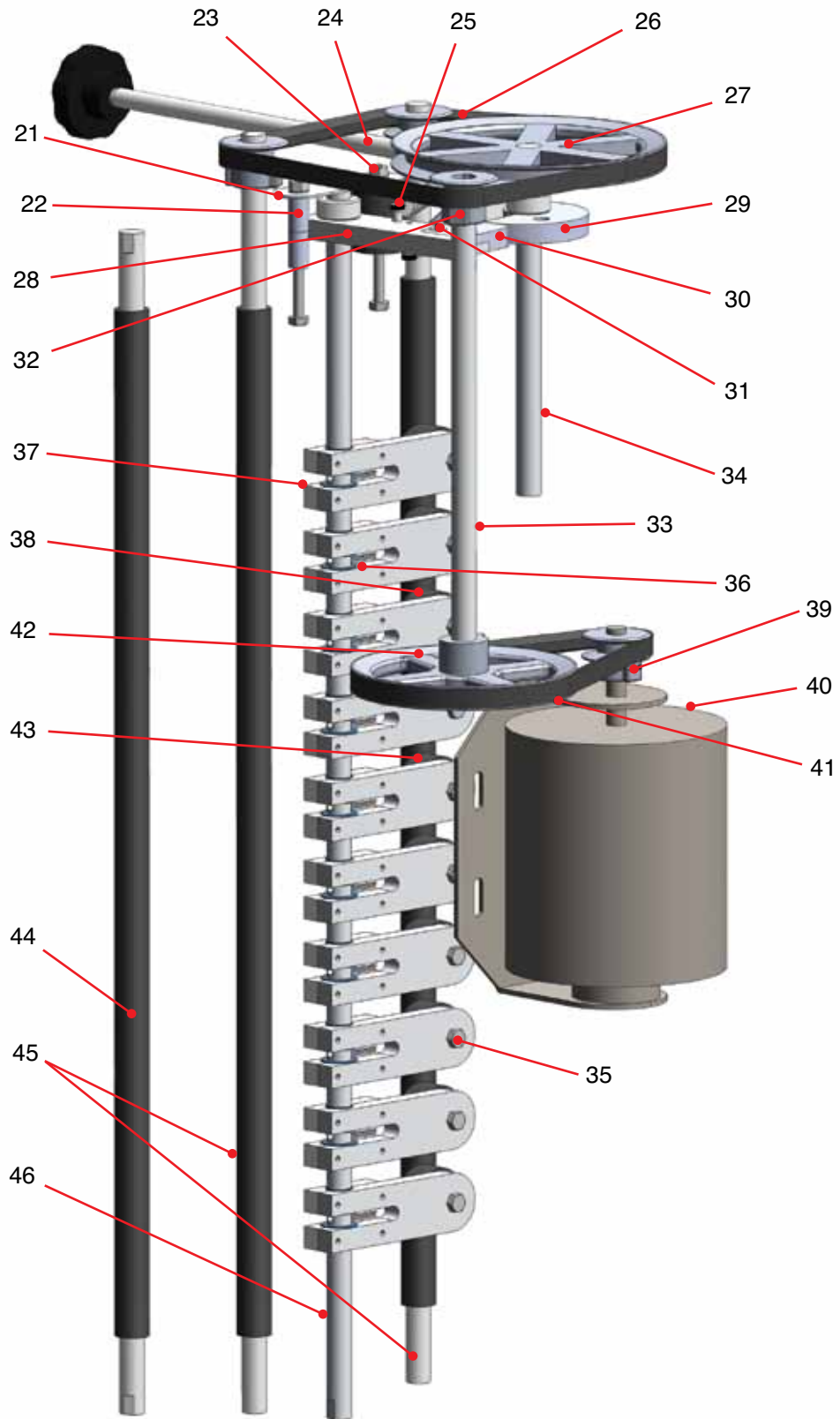

SS-21 Internal Parts Diagram

7.2 SS-21 Electrical Schematic

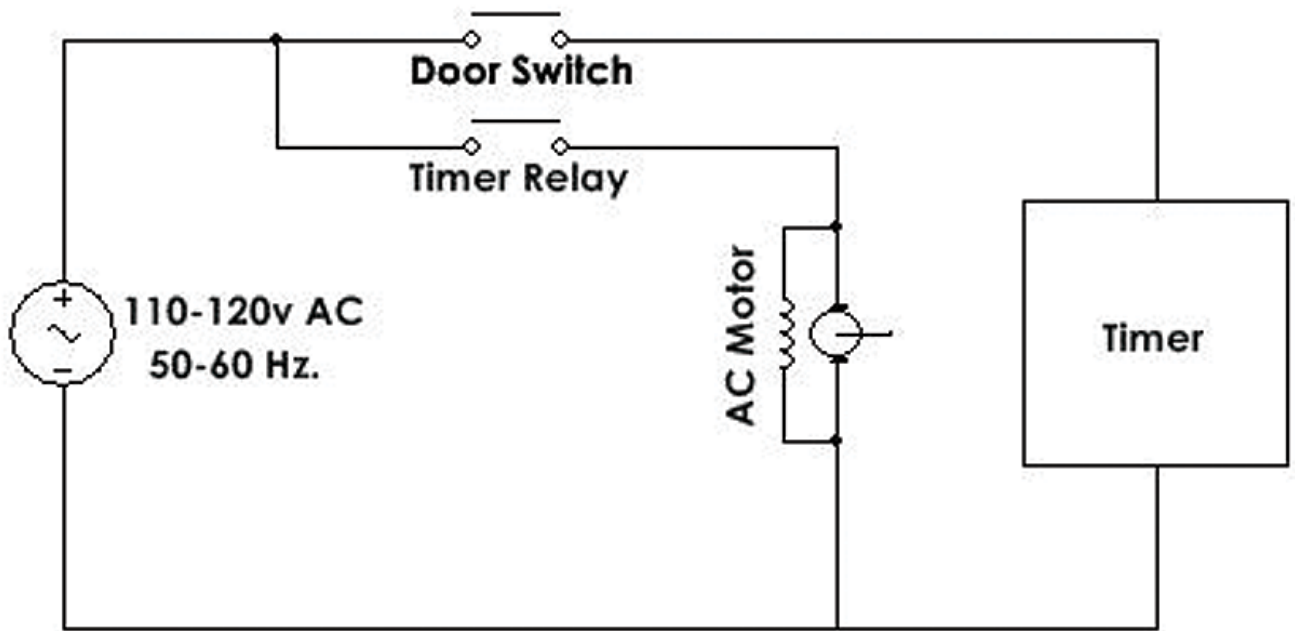

SS-21 Electrical Schematic

## 8.0 PARTS LIST:

### 8.1 SS-21 Parts List

Item No.	Part No.	No. Req'd	Description
1	SSA-76	1	Timer/Controller
2	WGSW-832050TPMSS	6	Machine Screw (#8-32 x 0.5in Lg.)
3	WGRA-HANDLE	1	Door Handle
4	WGSW-516125PMSS	2	Machine Screw (5/16-18 x 1.25in Lg.)
5	WGSW-252100FAMSB	16	Machine Screw (1/4-20 x 1.00" Lg.)
6	WGSW-252075FAMSB	16	Machine Screw (1/4-20 x 0.75in Lg.)
7	WGRA-PULLHANDLE	1	Mount For Pull Handle
8	WGRA-PULLKNOB	1	Pull Handle Knob
9	WGSW-252200HHMSS	4	Bolt (1/4-20 x 2in Lg.)
10	WGSW-252125HHMSS	8	Bolt (1/4-20 x 1.25" Lg.)
11	WGRA-ROTATEPOST	2	Pivot Post
12	WGRA-GUIDEBRKT	1	Tilt Guide
13	WGRA-STOPPER	2	Tilt Stop
14	WGRA-STPRCAPS	2	Tilt Stop Cap
15	WGRA-CROSSRAIL	2	Frame Cross Rail
16	WGNT-386HXSESZ	4	3/8-16 Self Locking Nut
17	WGSW-252300HHMSS	4	Bolt (1/4-20 x 3in Lg.)
18	WGRA-CASTERS	4	Locking Caster
19	WGWA-250FLNOSS	8	Washer (1/4 in)
20	WGRA-252HXNYSS	4	Lock Nut (1/4-20)
21	WGRA-CHS_Bracket	1	Silencer Bracket
22	WGSW-252075RUNY050	4	Nylon Standoff
23	WGNT-252HXNYSS	4	Lock Nut (1/4-20)
24	WGRA-SPRINGROD	1	Tensioner Rod
25	WGSW-SB-0204025038CAMSS	2	Machine Screw (#8-32 x 4/2 Lg.)
26	WGRA-VBELTUPPER	1	Upper V-Belt
27	WGRA-700X625PULLEY	1	Cam Pulley
28	WGRA-CAMARM	1	Cam Hammer Arm
29	WGRA-CAM	1	Cam
30	WGRA-CAMHAMMERHEAD	1	Cam Hammer Head
31	WGRA-024038TPMSS	2	Machine Screw (#10-24 x 0.375in Lg.)
32	WGRA-175X625PULLEY	3	Rod Pulley
33	WGRA-ROD13	1	Drive Shaft Rod
34	WGRA-ROD9	1	Cam Rod
35	WGSW-252100HHMSS	10	Bolt (1/4-20 x 1in Lg.)
36	WGRA-NYLINER	20	Nylon Spacer
37	SSA-72	10	Hammer Assembly
38	SSA-74	10	Hammer Head
39	WGRA-175X500 PULLEY	1	Motor Pulley
40	WGRA-MOTOR	1	Motor
41	WGRA-VBELTLLOWER	1	Lower V-Belt
42	WGRA-600X625PULLEY	1	Drive Pulley
43	WGRA-HAMMERCOVER	10	Hammer Cover
44	WGRA-RODIDLER	1	Idle Rod
45	WGRA-RODDRIVER	2	Driver Rod
46	WGRA-HAMMERROD	1	Hammer Rod

## 9.0 ADDITIONAL INFORMATION:

### 9.1 Gilson Test Sieves

Gilson stocks the widest range and largest quantity of sieves of any major supplier. Immediate shipment is available for all popular sizes. Custom sieves with special diameters and stacking heights are also available.

ASTM Sieves meet the requirements of ASTM E 11. ISO Sieves meet ISO 565 specifications with tolerances to ISO 3310-1. All are serial numbered and supplied with a certificate of manufacturing conformance.

ASTM and ISO Test Sieves are categorized in three different classes.

- **Compliance Test Sieves** are supplied with a basic certificate of manufacturing conformance. All Gilson Test Sieves meet Compliance grade requirements.
- **Inspection Test Sieves** have a specified number of openings measured and reported for each sieve.
- **Calibration Test Sieves** have two to three times as many openings measured on each sieve, and are supplied with more detailed documentation.

#### Mesh Opening

Opening Sizes are listed using standard millimeter (mm) or micrometer (µm) descriptions, as well as traditional inch and number designations where appropriate. Gilson offers all mesh sizes, but not all sizes are available in every frame diameter. Common coarse sizes are also

listed. Normally, every second or fourth size is used, although precision testing may require consecutive sizes. Additional sieves are often inserted into the sequence to avoid overloading of individual sieves or to better define a particular size range.

ISO Sieve Cloth can be mounted in 8in (203mm) frames when special-ordered. These items are nonreturnable when supplied as ordered.

#### Frame Diameter

Frames should accommodate the entire sample volume with enough surface area to avoid overloading individual sieves. The diameter selected must also fit the sieve shaker being used. Gilson stocks most common sizes. Inquire for custom sizes.

#### Frame Height

Sieve frames are designated as Full-Height or Half-Height. Intermediate-Height sieves are also available for 3in and 12in diameters. Half or Intermediate-Height frames allow a greater number of sieves to be used when stack height is limited. Full-Height frames allow free movement of larger particles during agitation for more efficient separation. ISO Test Sieves are fitted with black rubber O-Rings.

#### Frame and Cloth Material

- **Stainless Steel Frame with Stainless Steel Cloth** assures a sieve with the longest possible service life. This is the best choice where contamination, sanitation or extreme wear is an issue.

SIEVE FRAME HEIGHTS & PARTICLE TOPSIZE LIMITS					
Sieve		Frame Height		Particle Topsize	
Diameter	Frame Designation	Stacked	Overall	Recommended	Limit
3in (75mm)	FH	1-1/8	1-3/4	No.8	3/8in
	IH	1	1-1/2	No.8	3/8in
	HH	5/8	1-1/4	No.8	1/4in
6in (152mm)	FH	1-7/8	2-5/8	No.4	1/2in
	HH	1-1/8	1-7/8	No.4	3/8in
8in (203mm)	FH	2-1/8	2-5/8	No.4	1/2in
	HH	1-1/8	1-5/8	No.4	3/8in
200mm	FH	2-1/8	2-5/8	No.4	1/2in
	HH	1-1/8	1-5/8	No.4	3/8in
10in (254mm)	FH	3-1/8	4	3/8in	3/4in
12in (305mm)	FH	3-3/8	4-1/4	1/2in	1in
	IH	2-1/8	3	1/2in	3/4in
	HH	1-3/4	2-5/8	1/2in	1/2in
300mm	FH	2-1/2	3	1/2in	3/4in
	HH	1-1/2	2	1/2in	1/2in
18in (457mm)	FH	4-1/4	5-1/2	1-1/2in	2in

- Brass Frame with Stainless Steel Cloth is a popular choice that offers extended service and cost-effectiveness.
- Brass Frame with Brass Cloth is economical for light-duty applications. Coarse-series sieves are not available with brass cloth.

### Backing Cloth

Back-up cloth prevents sagging or tearing of expensive fine stainless steel mesh. Unsatisfactory service life from a sieve would suggest replacement by a sieve built with backing cloth. To order, add the code "BU" to the model number of the sieve. These sieves are made-to-order, have longer delivery times and are non-returnable.

### Pans and Covers

- Pans collect fines at the bottom of the sieve stack. Extended-Rim pans are also available to insert into the middle of a stack, allowing two samples to be tested at once.
- Covers are not necessary with most Gilson sieve shakers, but may be needed if using a different shaker or shaking by hand. The Cover-with-Ring has a wire finger loop in the center to facilitate removal.

### Gilson Sieve Verification Services

Gilson Verification can be performed on any test sieve or Gilson screen tray, used or new. These services are ordered by specifying the appropriate model number given in our listing for Test Sieve and Screen Tray Verification and Services. An optical comparator with NIST traceable calibration measures opening sizes and wire diameters on each sieve, and a statistical analysis assures the standard deviations are within ASTM or ISO requirements for Inspection or Calibration grades. Sieves, trays, or wire cloth units are not included in the purchase price of the verification services. Because wire cloth stretches, sags, or tears, and abrasive materials can reduce wire diameters, a verification process should also be set up to regularly verify that working sieves still meet the specifications. These measurements can be taken directly using calipers or an optical comparator, by testing with Standard Reference Materials, or by returning to Gilson for Re-Verification. To verify used sieves, contact a Gilson customer service representative for shipping instructions.

### Standard Reference Materials (SRM's)

Sieve Reference Materials are precision glass beads or powders for performance testing of sieves. They are traceable to the National Institute of Standards and Technology (NIST), or European Community Bureau of Reference (BCR). SRM's fit easily into internal quality programs following guidelines in ASTM E 2427, *Sieve Acceptance by Performance Testing*. User-Prepared Reference Materials can also be utilized under E 2427

in the same manner as SRM's. Because user materials are non-standard, they are not traceable and require much more handling. In addition, the user must determine acceptable tolerances for statistical analysis.

### Sieve Shakers

The proper sieve shaker saves considerable time and effort, and yields superior accuracy, consistency, and repeatability compared to manual shaking methods for particle sizing. Effective agitation lifts all particles off the sieve cloth, reorients them, and allows them to be repeatedly "tried" to different openings at different angles. Careful review of shaker specifications allows optimal choices for different materials and applications. Greater sample volumes and large particle topsize may indicate selection of Gilson Test-Master®, Testing Screen or Porta-Screen® models for efficient processing.

### 9.2 Test Sieve & Screen Tray Verification & Services

There have been extensive revisions to the newest version of ASTM standard E 11, *Specification for Wire Cloth and Sieves for Testing Purposes*. Gilson is leading the way in educating our customers about the new specification and making these new products available. The new specification affects all test sieves, screen trays, and wire cloth, and changes the way the mesh openings are evaluated by looking at the statistical distribution of aperture sizes, rather than just the average opening sizes. In addition to a more accurate and reliable system of evaluation, the new system also allows compatibility with ISO 565 and 3310-1 requirements. There are now three grades, or classes of ASTM or ISO test sieves available; Compliance, Inspection and Calibration.

- **Compliance Test Sieves** are manufactured with wire cloth that has been inspected and measured in roll or sheet quantities prior to being cut and mounted in the individual sieve frames. Opening sizes are not measured in individual sieves. Each Compliance sieve is supplied with a certificate of manufacturing compliance, but no statistical documentation is given. Compliance sieves are designed for applications where a basic, reliable degree of accuracy and repeatability are sufficient.
- **Inspection Test Sieves** have a specified number of openings measured in each sieve after the cloth is mounted in the frame. There is a 99% confidence level that the standard deviation of these openings is within the maximum allowed by ASTM. Inspection Sieves are a good choice in applications where accuracy and repeatability are critical. Each Inspection Sieve consists of a Compliance Sieve with added Inspection Sieve Verification service.

- **Calibration Test Sieves** have about twice as many openings measured as Inspection Sieves. The higher number of openings measured on each sieve increases the confidence level to 99.73% that the standard deviation of these openings is within the maximum allowed by ASTM. Calibration Sieves should be used in applications where a very high degree of accuracy is required. Each Calibration Sieve consists of a compliance sieve with added Calibration Sieve Verification service.

New Gilson Test Sieves are guaranteed to meet the requirements of ASTM or ISO for Compliance, Inspection or Calibration grades as ordered, but for continued assurance of performance, procedures should be in place to regularly check working sieves as they age. Wire cloth stretches, sags, or even tears, and abrasive materials reduce wire diameter, causing an increase in opening size and loss of accuracy over time.

These same verification services are also available for screen trays used in Gilson Testing Screens, Test-Master®, Porta-Screen® and Gilso-Matic® machines.

**Gilson Reverification Services** can be performed on used ASTM or ISO Test Sieves or Screen Trays. An optical comparator with NIST traceable calibration measures opening and wire diameter sizes on each sieve. Certification reports are produced for the appropriate grade. These services are available for all ASTM and ISO sieve sizes and types, and are ordered by specifying model numbers for Inspection Sieve Verification, or Calibration Sieve Verification. Sieves are not included in the purchase price. When verifying used sieves, contact a Gilson customer service representative for shipping instructions.

**Master-Matched Sieves** are ASTM 8in diameter stainless woven-wire sieves from No.8 (2.36mm) to No.325 (45µm) that have been measured and shown to closely match a set of master sieves maintained by Gilson in a reference laboratory. Master-Matched Sieves from Gilson are always matched to the same master set, assuring that one sieve is very close to another. Master-Matched Sieves are also certified to meet ASTM E 11, so additional verification is not normally necessary. Master-Matching is done using special standard reference materials, sized for each sieve. Each sieve is performance tested to insure it yields ±2% by weight of the value of the master sieve.

**Ordering**

All Gilson test sieves meet ASTM or ISO requirements for Compliance Test Sieves. Ordering additional verification services for each individual sieve upgrades them to meet Inspection or Calibration specifications.



**GV-65 Calibration Verification shown with Sieve**



**Certificate of E 11 Compliance for all Sieves**

TEST SIEVE & SCREEN TRAY VERIFICATION & SERVICES	
Description	Model
Inspection Test Sieve Verification, ASTM E 11	GV-60
Calibration Test Sieve Verification, ASTM E 11	GV-65
Inspection Test Sieve Verification, ISO 565 and 3310-1	GV-62
Calibration Test Sieve Verification, ISO 565 and 3310-1	GV-63
Inspection Screen Tray Verification, ASTM E 11	GV-61
Calibration Screen Tray Verification, ASTM E 11	GV-66
Inspection Screen Tray Verification, ISO 565 and 3310-1	GV-64
Calibration Screen Tray Verification, ISO 565 and 3310-1	GV-67
Master-Matched Sieves	MM-70

**9.3 8in Diameter ASTM Test Sieves**

8IN DIAMETER ASTM TEST SIEVES								
	ASTM		Brass Cloth Brass Frame		Stainless Cloth Brass Frame		Stainless Cloth Stainless Frame	
			Full Ht.	Half Ht.	Full Ht.	Half Ht.	Full Ht.	Half Ht.
<b>C O A R S E  S E R I E S</b>	4in	100.0mm	—	—	V8CF 4"	V8CH 4"	V8SF 4"	—
	3-1/2in	90.0mm	—	—	V8CF 3-1/2"	V8CH 3-1/2"	V8SF 3-1/2"	—
	3in	75.0mm	—	—	V8CF 3"	V8CH 3"	V8SF 3"	—
	2-1/2in	63.0mm	—	—	V8CF 2-1/2"	V8CH 2-1/2"	V8SF 2-1/2"	—
	2.12in	53.0mm	—	—	V8CF 2.12"	V8CH 2.12"	V8SF 2.12"	—
	2in	50.0mm	—	—	V8CF 2"	V8CH 2"	V8SF 2"	—
	1-3/4in	45.0mm	—	—	V8CF 1-3/4"	V8CH 1-3/4"	V8SF 1-3/4"	—
	1-1/2in	37.5mm	—	—	V8CF 1-1/2"	V8CH 1-1/2"	V8SF 1-1/2"	—
	1-1/4in	31.5mm	—	—	V8CF 1-1/4"	V8CH 1-1/4"	V8SF 1-1/4"	—
	1.06in	26.5mm	—	—	V8CF 1.06"	V8CH 1.06"	V8SF 1.06"	—
	1in	25.0mm	—	—	V8CF 1"	V8CH 1"	V8SF 1"	V8SH 1"
	7/8in	22.4mm	—	—	V8CF 7/8"	V8CH 7/8"	V8SF 7/8"	V8SH 7/8"
	3/4in	19.0mm	—	—	V8CF 3/4"	V8CH 3/4"	V8SF 3/4"	V8SH 3/4"
	5/8in	16.0mm	—	—	V8CF 5/8"	V8CH 5/8"	V8SF 5/8"	V8SH 5/8"
	0.530in	13.2mm	—	—	V8CF .530"	V8CH .530"	V8SF .530"	V8SH .530"
	1/2in	12.5mm	—	—	V8CF 1/2"	V8CH 1/2"	V8SF 1/2"	V8SH 1/2"
	7/16in	11.2mm	—	—	V8CF 7/16"	V8CH 7/16"	V8SF 7/16"	V8SH 7/16"
	3/8in	9.5mm	—	—	V8CF 3/8"	V8CH 3/8"	V8SF 3/8"	V8SH 3/8"
	5/16in	8.0mm	—	—	V8CF 5/16"	V8CH 5/16"	V8SF 5/16"	V8SH 5/16"
	0.265in	6.7mm	—	—	V8CF .265"	V8CH .265"	V8SF .265"	V8SH .265"
1/4in	6.3mm	—	—	V8CF 1/4"	V8CH 1/4"	V8SF 1/4"	V8SH 1/4"	
No.3-1/2	5.6mm	V8BF #3-1/2	V8BH #3-1/2	V8CF #3-1/2	V8CH #3-1/2	V8SF #3-1/2	V8SH #3-1/2	
No.4	4.75mm	V8BF #4	V8BH #4	V8CF #4	V8CH #4	V8SF #4	V8SH #4	
<b>F I N E  S E R I E S</b>	No.5	4.0mm	V8BF #5	V8BH #5	V8CF #5	V8CH #5	V8SF #5	V8SH #5
	No.6	3.35mm	V8BF #6	V8BH #6	V8CF #6	V8CH #6	V8SF #6	V8SH #6
	1/8in <sup>1</sup>	3.18mm	—	—	V8CF 1/8"	V8CH 1/8"	V8SF 1/8"	V8SH 1/8"
	No.7	2.8mm	V8BF #7	V8BH #7	V8CF #7	V8CH #7	V8SF #7	V8SH #7
	No.8	2.36mm	V8BF #8	V8BH #8	V8CF #8	V8CH #8	V8SF #8	V8SH #8
	No.10	2.0mm	V8BF #10	V8BH #10	V8CF #10	V8CH #10	V8SF #10	V8SH #10
	No.12	1.7mm	V8BF #12	V8BH #12	V8CF #12	V8CH #12	V8SF #12	V8SH #12
	No.14	1.4mm	V8BF #14	V8BH #14	V8CF #14	V8CH #14	V8SF #14	V8SH #14
	No.16	1.18mm	V8BF #16	V8BH #16	V8CF #16	V8CH #16	V8SF #16	V8SH #16
	No.18	1.0mm	V8BF #18	V8BH #18	V8CF #18	V8CH #18	V8SF #18	V8SH #18
	No.20	850µm	V8BF #20	V8BH #20	V8CF #20	V8CH #20	V8SF #20	V8SH #20
	No.25	710µm	V8BF #25	V8BH #25	V8CF #25	V8CH #25	V8SF #25	V8SH #25
	No.30	600µm	V8BF #30	V8BH #30	V8CF #30	V8CH #30	V8SF #30	V8SH #30
	No.35	500µm	V8BF #35	V8BH #35	V8CF #35	V8CH #35	V8SF #35	V8SH #35
	No.40	425µm	V8BF #40	V8BH #40	V8CF #40	V8CH #40	V8SF #40	V8SH #40
	No.45	355µm	V8BF #45	V8BH #45	V8CF #45	V8CH #45	V8SF #45	V8SH #45
	No.50	300µm	V8BF #50	V8BH #50	V8CF #50	V8CH #50	V8SF #50	V8SH #50
	No.60	250µm	V8BF #60	V8BH #60	V8CF #60	V8CH #60	V8SF #60	V8SH #60
	No.70	212µm	V8BF #70	V8BH #70	V8CF #70	V8CH #70	V8SF #70	V8SH #70
	No.80	180µm	V8BF #80	V8BH #80	V8CF #80	V8CH #80	V8SF #80	V8SH #80
	No.100	150µm	V8BF #100	V8BH #100	V8CF #100	V8CH #100	V8SF #100	V8SH #100
	No.120	125µm	V8BF #120	V8BH #120	V8CF #120	V8CH #120	V8SF #120	V8SH #120
	No.140	106µm	V8BF #140	V8BH #140	V8CF #140	V8CH #140	V8SF #140	V8SH #140
	No.170	90µm	V8BF #170	V8BH #170	V8CF #170	V8CH #170	V8SF #170	V8SH #170
	No.200	75µm	V8BF #200	V8BH #200	V8CF #200	V8CH #200	V8SF #200	V8SH #200
	No.230	63µm	V8BF #230	V8BH #230	V8CF #230	V8CH #230	V8SF #230	V8SH #230
	No.270	53µm	V8BF #270	V8BH #270	V8CF #270	V8CH #270	V8SF #270	V8SH #270
	No.325	45µm	V8BF #325	V8BH #325	V8CF #325	V8CH #325	V8SF #325	V8SH #325
	No.400	38µm	V8BF #400	V8BH #400	V8CF #400	V8CH #400	V8SF #400	V8SH #400
	No.450	32µm	—	—	V8CF #450	V8CH #450	V8SF #450	V8SH #450
No.500	25µm	—	—	V8CF #500	V8CH #500	V8SF #500	V8SH #500	
No.635	20µm	—	—	V8CF #635	V8CH #635	V8SF #635	V8SH #635	
Regular Pan		V8BFXPN	V8BHXPN	V8BFXPN	V8BHXPN	V8SFXPN	V8SHXPN	
Extended Rim Pan		V8BFXPE	V8BHXPE	V8BFXPE	V8BHXPE	V8SFXPE	V8SHXPE	
Regular Cover		V8BFXCV		V8BFXCV		V8SFXCV		
Cover with Ring		V8BFXCR		V8BFXCR		V8SFXCR		



**8in Round Test Sieves**



**SS-21**

<sup>1</sup> Not a standard ASTM E 11 size.

9.4 12in Diameter ASTM Test Sieves

12IN DIAMETER ASTM TEST SIEVES											
	ASTM		Brass Cloth Brass Frame			Stainless Cloth Brass Frame			Stainless Cloth Stainless Frame		
			Full Ht.	Inter. Ht.	Half Ht.	Full Ht.	Inter. Ht.	Half Ht.	Full Ht.	Inter. Ht.	Half Ht.
<b>C O A R S E  S E R I E S</b>	4in	100.0mm	—	—	—	V12CF 4"	V12CI 4"	V12CH 4"	V12SF 4"	V12SI 4"	V12SH 4"
	3-1/2in	90.0mm	—	—	—	V12CF 3-1/2"	V12CI 3-1/2"	V12CH 3-1/2"	V12SF 3-1/2"	V12SI 3-1/2"	V12SH 3-1/2"
	3in	75.0mm	—	—	—	V12CF 3"	V12CI 3"	V12CH 3"	V12SF 3"	V12SI 3"	V12SH 3"
	2-1/2in	63.0mm	—	—	—	V12CF 2-1/2"	V12CI 2-1/2"	V12CH 2-1/2"	V12SF 2-1/2"	V12SI 2-1/2"	V12SH 2-1/2"
	2.12in	53.0mm	—	—	—	V12CF 2.12"	V12CI 2.12"	V12CH 2.12"	V12SF 2.12"	V12SI 2.12"	V12SH 2.12"
	2in	50.0mm	—	—	—	V12CF 2"	V12CI 2"	V12CH 2"	V12SF 2"	V12SI 2"	V12SH 2"
	1-3/4in	45.0mm	—	—	—	V12CF 1-3/4"	V12CI 1-3/4"	V12CH 1-3/4"	V12SF 1-3/4"	V12SI 1-3/4"	V12SH 1-3/4"
	1-1/2in	37.5mm	—	—	—	V12CF 1-1/2"	V12CI 1-1/2"	V12CH 1-1/2"	V12SF 1-1/2"	V12SI 1-1/2"	V12SH 1-1/2"
	1-1/4in	31.5mm	—	—	—	V12CF 1-1/4"	V12CI 1-1/4"	V12CH 1-1/4"	V12SF 1-1/4"	V12SI 1-1/4"	V12SH 1-1/4"
	1.06in	26.5mm	—	—	—	V12CF 1.06"	V12CI 1.06"	V12CH 1.06"	V12SF 1.06"	V12SI 1.06"	V12SH 1.06"
	1in	25.0mm	—	—	—	V12CF 1"	V12CI 1"	V12CH 1"	V12SF 1"	V12SI 1"	V12SH 1"
	7/8in	22.4mm	—	—	—	V12CF 7/8"	V12CI 7/8"	V12CH 7/8"	V12SF 7/8"	V12SI 7/8"	V12SH 7/8"
	3/4in	19.0mm	—	—	—	V12CF 3/4"	V12CI 3/4"	V12CH 3/4"	V12SF 3/4"	V12SI 3/4"	V12SH 3/4"
	5/8in	16.0mm	—	—	—	V12CF 5/8"	V12CI 5/8"	V12CH 5/8"	V12SF 5/8"	V12SI 5/8"	V12SH 5/8"
	0.530in	13.2mm	—	—	—	V12CF .530"	V12CI .530"	V12CH .530"	V12SF .530"	V12SI .530"	V12SH .530"
	1/2in	12.5mm	—	—	—	V12CF 1/2"	V12CI 1/2"	V12CH 1/2"	V12SF 1/2"	V12SI 1/2"	V12SH 1/2"
	7/16in	11.2mm	—	—	—	V12CF 7/16"	V12CI 7/16"	V12CH 7/16"	V12SF 7/16"	V12SI 7/16"	V12SH 7/16"
	3/8in	9.5mm	—	—	—	V12CF 3/8"	V12CI 3/8"	V12CH 3/8"	V12SF 3/8"	V12SI 3/8"	V12SH 3/8"
	5/16in	8.0mm	—	—	—	V12CF 5/16"	V12CI 5/16"	V12CH 5/16"	V12SF 5/16"	V12SI 5/16"	V12SH 5/16"
	0.265in	6.7mm	—	—	—	V12CF .265"	V12CI .265"	V12CH .265"	V12SF .265"	V12SI .265"	V12SH .265"
1/4in	6.3mm	—	—	—	V12CF 1/4"	V12CI 1/4"	V12CH 1/4"	V12SF 1/4"	V12SI 1/4"	V12SH 1/4"	
No.3-1/2	5.6mm	—	—	—	V12CF #3-1/2	V12CI #3-1/2	V12CH #3-1/2	V12SF #3-1/2	V12SI #3-1/2	V12SH #3-1/2	
No.4	4.75mm	—	—	—	V12CF #4	V12CI #4	V12CH #4	V12SF #4	V12SI #4	V12SH #4	
<b>F I N E  S E R I E S</b>	No.5	4.0mm	—	—	—	V12CF #5	V12CI #5	V12CH #5	V12SF #5	V12SI #5	V12SH #5
	No.6	3.35mm	—	—	—	V12CF #6	V12CI #6	V12CH #6	V12SF #6	V12SI #6	V12SH #6
	1/8in <sup>1</sup>	3.18mm	—	—	—	V12CF 1/8"	V12CI 1/8"	V12CH 1/8"	V12SF 1/8"	V12SI 1/8"	V12SH 1/8"
	No.7	2.8mm	—	—	—	V12CF #7	V12CI #7	V12CH #7	V12SF #7	V12SI #7	V12SH #7
	No.8	2.36mm	V12BF #8	V12BI #8	V12BH #8	V12CF #8	V12CI #8	V12CH #8	V12SF #8	V12SI #8	V12SH #8
	No.10	2.0mm	V12BF #10	V12BI #10	V12BH #10	V12CF #10	V12CI #10	V12CH #10	V12SF #10	V12SI #10	V12SH #10
	No.12	1.7mm	V12BF #12	V12BI #12	V12BH #12	V12CF #12	V12CI #12	V12CH #12	V12SF #12	V12SI #12	V12SH #12
	No.14	1.4mm	V12BF #14	V12BI #14	V12BH #14	V12CF #14	V12CI #14	V12CH #14	V12SF #14	V12SI #14	V12SH #14
	No.16	1.18mm	V12BF #16	V12BI #16	V12BH #16	V12CF #16	V12CI #16	V12CH #16	V12SF #16	V12SI #16	V12SH #16
	No.18	1.0mm	V12BF #18	V12BI #18	V12BH #18	V12CF #18	V12CI #18	V12CH #18	V12SF #18	V12SI #18	V12SH #18
	No.20	850µm	V12BF #20	V12BI #20	V12BH #20	V12CF #20	V12CI #20	V12CH #20	V12SF #20	V12SI #20	V12SH #20
	No.25	710µm	V12BF #25	V12BI #25	V12BH #25	V12CF #25	V12CI #25	V12CH #25	V12SF #25	V12SI #25	V12SH #25
	No.30	600µm	V12BF #30	V12BI #30	V12BH #30	V12CF #30	V12CI #30	V12CH #30	V12SF #30	V12SI #30	V12SH #30
	No.35	500µm	V12BF #35	V12BI #35	V12BH #35	V12CF #35	V12CI #35	V12CH #35	V12SF #35	V12SI #35	V12SH #35
	No.40	425µm	V12BF #40	V12BI #40	V12BH #40	V12CF #40	V12CI #40	V12CH #40	V12SF #40	V12SI #40	V12SH #40
	No.45	355µm	V12BF #45	V12BI #45	V12BH #45	V12CF #45	V12CI #45	V12CH #45	V12SF #45	V12SI #45	V12SH #45
	No.50	300µm	V12BF #50	V12BI #50	V12BH #50	V12CF #50	V12CI #50	V12CH #50	V12SF #50	V12SI #50	V12SH #50
	No.60	250µm	V12BF #60	V12BI #60	V12BH #60	V12CF #60	V12CI #60	V12CH #60	V12SF #60	V12SI #60	V12SH #60
	No.70	212µm	V12BF #70	V12BI #70	V12BH #70	V12CF #70	V12CI #70	V12CH #70	V12SF #70	V12SI #70	V12SH #70
	No.80	180µm	V12BF #80	V12BI #80	V12BH #80	V12CF #80	V12CI #80	V12CH #80	V12SF #80	V12SI #80	V12SH #80
No.100	150µm	V12BF #100	V12BI #100	V12BH #100	V12CF #100	V12CI #100	V12CH #100	V12SF #100	V12SI #100	V12SH #100	
No.120	125µm	V12BF #120	V12BI #120	V12BH #120	V12CF #120	V12CI #120	V12CH #120	V12SF #120	V12SI #120	V12SH #120	
No.140	106µm	V12BF #140	V12BI #140	V12BH #140	V12CF #140	V12CI #140	V12CH #140	V12SF #140	V12SI #140	V12SH #140	
No.170	90µm	V12BF #170	V12BI #170	V12BH #170	V12CF #170	V12CI #170	V12CH #170	V12SF #170	V12SI #170	V12SH #170	
No.200	75µm	V12BF #200	V12BI #200	V12BH #200	V12CF #200	V12CI #200	V12CH #200	V12SF #200	V12SI #200	V12SH #200	
No.230	63µm	V12BF #230	V12BI #230	V12BH #230	V12CF #230	V12CI #230	V12CH #230	V12SF #230	V12SI #230	V12SH #230	
No.270	53µm	V12BF #270	V12BI #270	V12BH #270	V12CF #270	V12CI #270	V12CH #270	V12SF #270	V12SI #270	V12SH #270	
No.325	45µm	V12BF #325	V12BI #325	V12BH #325	V12CF #325	V12CI #325	V12CH #325	V12SF #325	V12SI #325	V12SH #325	
No.400	38µm	—	V12BI #400	V12BH #400	V12CF #400	V12CI #400	V12CH #400	V12SF #400	V12SI #400	V12SH #400	
No.450	32µm	—	—	—	V12CF #450	V12CI #450	V12CH #450	V12SF #450	V12SI #450	V12SH #450	
No.500	25µm	—	—	—	V12CF #500	V12CI #500	V12CH #500	V12SF #500	V12SI #500	V12SH #500	
No.635	20µm	—	—	—	V12CF #635	V12CI #635	V12CH #635	V12SF #635	V12SI #635	V12SH #635	
Regular Pan			V12BFXPN	V12BIXPN	V12BHXPN	V12BFXPN	V12BIXPN	V12BHXPN	V12SFXPN	—	V12SHXPN
Extended Rim Pan			V12BFXPE	V12BIXPE	V12BHXPE	V12BFXPE	V12BIXPE	V12BHXPE	V12SFXPE	V12SIXPE	V12SHXPE
Regular Cover			V12BFXCV			V12BFXCV			V12SFXCV		
Cover with Ring			V12BFXCR			V12BFXCR			V12SFXCR		

<sup>1</sup> Not a standard ASTM E 11 size.

9.5 ISO 200/300mm Test Sieves

ISO 200/300MM TEST SIEVES							
	ISO 565, 3310-1	200mm				300mm	
		Stainless Cloth Brass Frame		Stainless Cloth Stainless Frame		Stainless Cloth Stainless Frame	
		Full Ht.	Half Ht.	Full Ht.	Half Ht.	Full Ht.	Half Ht.
<b>C O A R S E S E R I E S</b>	63.0mm	V200CF 63M	V200CH 63M	V200SF 63M	V200SH 63M	V300SF 63M	V300SH 63M
	56.0mm	V200CF 56M	V200CH 56M	V200SF 56M	V200SH 56M	V300SF 56M	V300SH 56M
	53.0mm	V200CF 53M	V200CH 53M	V200SF 53M	V200SH 53M	V300SF 53M	V300SH 53M
	50.0mm	V200CF 50M	V200CH 50M	V200SF 50M	V200SH 50M	V300SF 50M	V300SH 50M
	45.0mm	V200CF 45M	V200CH 45M	V200SF 45M	V200SH 45M	V300SF 45M	V300SH 45M
	40.0mm	V200CF 40M	V200CH 40M	V200SF 40M	V200SH 40M	V300SF 40M	V300SH 40M
	37.5mm	V200CF 37.5M	V200CH 37.5M	V200SF 37.5M	V200SH 37.5M	V300SF 37.5M	V300SH 37.5M
	35.5mm	V200CF 35.5M	V200CH 35.5M	V200SF 35.5M	V200SH 35.5M	V300SF 35.5M	V300SH 35.5M
	31.5mm	V200CF 31.5M	V200CH 31.5M	V200SF 31.5M	V200SH 31.5M	V300SF 31.5M	V300SH 31.5M
	28.0mm	V200CF 28M	V200CH 28M	V200SF 28M	V200SH 28M	V300SF 28M	V300SH 28M
	26.5mm	V200CF 26.5M	V200CH 26.5M	V200SF 26.5M	V200SH 26.5M	V300SF 26.5M	V300SH 26.5M
	25.0mm	V200CF 25M	V200CH 25M	V200SF 25M	V200SH 25M	V300SF 25M	V300SH 25M
	22.4mm	V200CF 22.4M	V200CH 22.4M	V200SF 22.4M	V200SH 22.4M	V300SF 22.4M	V300SH 22.4M
	20.0mm	V200CF 20M	V200CH 20M	V200SF 20M	V200SH 20M	V300SF 20M	V300SH 20M
	19.0mm	V200CF 19M	V200CH 19M	V200SF 19M	V200SH 19M	V300SF 19M	V300SH 19M
	18.0mm	V200CF 18M	V200CH 18M	V200SF 18M	V200SH 18M	V300SF 18M	V300SH 18M
	16.0mm	V200CF 16M	V200CH 16M	V200SF 16M	V200SH 16M	V300SF 16M	V300SH 16M
	14.0mm	V200CF 14M	V200CH 14M	V200SF 14M	V200SH 14M	V300SF 14M	V300SH 14M
	13.2mm	V200CF 13.2M	V200CH 13.2M	V200SF 13.2M	V200SH 13.2M	V300SF 13.2M	V300SH 13.2M
	12.5mm	V200CF 12.5M	V200CH 12.5M	V200SF 12.5M	V200SH 12.5M	V300SF 12.5M	V300SH 12.5M
	11.2mm	V200CF 11.2M	V200CH 11.2M	V200SF 11.2M	V200SH 11.2M	V300SF 11.2M	V300SH 11.2M
	10.0mm	V200CF 10M	V200CH 10M	V200SF 10M	V200SH 10M	V300SF 10M	V300SH 10M
	9.5mm	V200CF 9.5M	V200CH 9.5M	V200SF 9.5M	V200SH 9.5M	V300SF 9.5M	V300SH 9.5M
	9.0mm	V200CF 9M	V200CH 9M	V200SF 9M	V200SH 9M	V300SF 9M	V300SH 9M
8.0mm	V200CF 8M	V200CH 8M	V200SF 8M	V200SH 8M	V300SF 8M	V300SH 8M	
7.1mm	V200CF 7.1M	V200CH 7.1M	V200SF 7.1M	V200SH 7.1M	V300SF 7.1M	V300SH 7.1M	
6.7mm	V200CF 6.7M	V200CH 6.7M	V200SF 6.7M	V200SH 6.7M	V300SF 6.7M	V300SH 6.7M	
6.3mm	V200CF 6.3M	V200CH 6.3M	V200SF 6.3M	V200SH 6.3M	V300SF 6.3M	V300SH 6.3M	
5.6mm	V200CF 5.6M	V200CH 5.6M	V200SF 5.6M	V200SH 5.6M	V300SF 5.6M	V300SH 5.6M	
5.0mm	V200CF 5M	V200CH 5M	V200SF 5M	V200SH 5M	V300SF 5M	V300SH 5M	
4.75mm	V200CF 4.75M	V200CH 4.75M	V200SF 4.75M	V200SH 4.75M	V300SF 4.75M	V300SH 4.75M	
4.50mm	V200CF 4.5M	V200CH 4.5M	V200SF 4.5M	V200SH 4.5M	V300SF 4.5M	V300SH 4.5M	
<b>F I N E S E R I E S</b>	4.00mm	V200CF 4M	V200CH 4M	V200SF 4M	V200SH 4M	V300SF 4M	V300SH 4M
	3.55mm	V200CF 3.55M	V200CH 3.55M	V200SF 3.55M	V200SH 3.55M	V300SF 3.55M	V300SH 3.55M
	3.35mm	V200CF 3.35M	V200CH 3.35M	V200SF 3.35M	V200SH 3.35M	V300SF 3.35M	V300SH 3.35M
	3.15mm	V200CF 3.15M	V200CH 3.15M	V200SF 3.15M	V200SH 3.15M	V300SF 3.15M	V300SH 3.15M
	2.80mm	V200CF 2.8M	V200CH 2.8M	V200SF 2.8M	V200SH 2.8M	V300SF 2.8M	V300SH 2.8M
	2.50mm	V200CF 2.5M	V200CH 2.5M	V200SF 2.5M	V200SH 2.5M	V300SF 2.5M	V300SH 2.5M
	2.36mm	V200CF 2.36M	V200CH 2.36M	V200SF 2.36M	V200SH 2.36M	V300SF 2.36M	V300SH 2.36M
	2.24mm	V200CF 2.24M	V200CH 2.24M	V200SF 2.24M	V200SH 2.24M	V300SF 2.24M	V300SH 2.24M
	2.00mm	V200CF 2M	V200CH 2M	V200SF 2M	V200SH 2M	V300SF 2M	V300SH 2M
	1.80mm	V200CF 1.8M	V200CH 1.8M	V200SF 1.8M	V200SH 1.8M	V300SF 1.8M	V300SH 1.8M
	1.70mm	V200CF 1.7M	V200CH 1.7M	V200SF 1.7M	V200SH 1.7M	V300SF 1.7M	V300SH 1.7M
	1.60mm	V200CF 1.6M	V200CH 1.6M	V200SF 1.6M	V200SH 1.6M	V300SF 1.6M	V300SH 1.6M
	1.40mm	V200CF 1.4M	V200CH 1.4M	V200SF 1.4M	V200SH 1.4M	V300SF 1.4M	V300SH 1.4M
	1.25mm	V200CF 1.25M	V200CH 1.25M	V200SF 1.25M	V200SH 1.25M	V300SF 1.25M	V300SH 1.25M
	1.18mm	V200CF 1.18M	V200CH 1.18M	V200SF 1.18M	V200SH 1.18M	V300SF 1.18M	V300SH 1.18M
	1.12mm	V200CF 1.12M	V200CH 1.12M	V200SF 1.12M	V200SH 1.12M	V300SF 1.12M	V300SH 1.12M
	1.00mm	V200CF 1M	V200CH 1M	V200SF 1M	V200SH 1M	V300SF 1M	V300SH 1M
	900µm	V200CF 900U	V200CH 900U	V200SF 900U	V200SH 900U	V300SF 900U	V300SH 900U
	850µm	V200CF 850U	V200CH 850U	V200SF 850U	V200SH 850U	V300SF 850U	V300SH 850U
	800µm	V200CF 800U	V200CH 800U	V200SF 800U	V200SH 800U	V300SF 800U	V300SH 800U
	710µm	V200CF 710U	V200CH 710U	V200SF 710U	V200SH 710U	V300SF 710U	V300SH 710U
	630µm	V200CF 630U	V200CH 630U	V200SF 630U	V200SH 630U	V300SF 630U	V300SH 630U
	600µm	V200CF 600U	V200CH 600U	V200SF 600U	V200SH 600U	V300SF 600U	V300SH 600U
	560µm	V200CF 560U	V200CH 560U	V200SF 560U	V200SH 560U	V300SF 560U	V300SH 560U
	500µm	V200CF 500U	V200CH 500U	V200SF 500U	V200SH 500U	V300SF 500U	V300SH 500U
	450µm	V200CF 450U	V200CH 450U	V200SF 450U	V200SH 450U	V300SF 450U	V300SH 450U
	425µm	V200CF 425U	V200CH 425U	V200SF 425U	V200SH 425U	V300SF 425U	V300SH 425U
	400µm	V200CF 400U	V200CH 400U	V200SF 400U	V200SH 400U	V300SF 400U	V300SH 400U
	355µm	V200CF 355U	V200CH 355U	V200SF 355U	V200SH 355U	V300SF 355U	V300SH 355U
	315µm	V200CF 315U	V200CH 315U	V200SF 315U	V200SH 315U	V300SF 315U	V300SH 315U
	300µm	V200CF 300U	V200CH 300U	V200SF 300U	V200SH 300U	V300SF 300U	V300SH 300U
	280µm	V200CF 280U	V200CH 280U	V200SF 280U	V200SH 280U	V300SF 280U	V300SH 280U
	250µm	V200CF 250U	V200CH 250U	V200SF 250U	V200SH 250U	V300SF 250U	V300SH 250U
	224µm	V200CF 224U	V200CH 224U	V200SF 224U	V200SH 224U	V300SF 224U	V300SH 224U
212µm	V200CF 212U	V200CH 212U	V200SF 212U	V200SH 212U	V300SF 212U	V300SH 212U	
200µm	V200CF 200U	V200CH 200U	V200SF 200U	V200SH 200U	V300SF 200U	V300SH 200U	
180µm	V200CF 180U	V200CH 180U	V200SF 180U	V200SH 180U	V300SF 180U	V300SH 180U	
160µm	V200CF 160U	V200CH 160U	V200SF 160U	V200SH 160U	V300SF 160U	V300SH 160U	
150µm	V200CF 150U	V200CH 150U	V200SF 150U	V200SH 150U	V300SF 150U	V300SH 150U	
140µm	V200CF 140U	V200CH 140U	V200SF 140U	V200SH 140U	V300SF 140U	V300SH 140U	
125µm	V200CF 125U	V200CH 125U	V200SF 125U	V200SH 125U	V300SF 125U	V300SH 125U	
112µm	V200CF 112U	V200CH 112U	V200SF 112U	V200SH 112U	V300SF 112U	V300SH 112U	
106µm	V200CF 106U	V200CH 106U	V200SF 106U	V200SH 106U	V300SF 106U	V300SH 106U	
100µm	V200CF 100U	V200CH 100U	V200SF 100U	V200SH 100U	V300SF 100U	V300SH 100U	
90µm	V200CF 90U	V200CH 90U	V200SF 90U	V200SH 90U	V300SF 90U	V300SH 90U	
80µm	V200CF 80U	V200CH 80U	V200SF 80U	V200SH 80U	V300SF 80U	V300SH 80U	
75µm	V200CF 75U	V200CH 75U	V200SF 75U	V200SH 75U	V300SF 75U	V300SH 75U	
71µm	V200CF 71U	V200CH 71U	V200SF 71U	V200SH 71U	V300SF 71U	V300SH 71U	
63µm	V200CF 63U	V200CH 63U	V200SF 63U	V200SH 63U	V300SF 63U	V300SH 63U	
56µm	V200CF 56U	V200CH 56U	V200SF 56U	V200SH 56U	V300SF 56U	V300SH 56U	
53µm	V200CF 53U	V200CH 53U	V200SF 53U	V200SH 53U	V300SF 53U	V300SH 53U	
50µm	V200CF 50U	V200CH 50U	V200SF 50U	V200SH 50U	V300SF 50U	V300SH 50U	
45µm	V200CF 45U	V200CH 45U	V200SF 45U	V200SH 45U	V300SF 45U	V300SH 45U	
40µm	V200CF 40U	V200CH 40U	V200SF 40U	V200SH 40U	V300SF 40U	V300SH 40U	
38µm	V200CF 38U	V200CH 38U	V200SF 38U	V200SH 38U	V300SF 38U	V300SH 38U	
36µm	V200CF 36U	V200CH 36U	V200SF 36U	V200SH 36U	V300SF 36U	V300SH 36U	
32µm	V200CF 32U	V200CH 32U	V200SF 32U	V200SH 32U	V300SF 32U	V300SH 32U	
25µm	V200CF 25U	V200CH 25U	V200SF 25U	V200SH 25U	V300SF 25U	V300SH 25U	
20µm	V200CF 20U	V200CH 20U	V200SF 20U	V200SH 20U	V300SF 20U	V300SH 20U	
Pan Cover	V200BF XPN V200B XCV	V200BH XPN V200B XCV	V200SF XPN V200S XCV	V200SH XPN V200S XCV	V300SF XPN V300S XCV	V300SH XPN V300S XCV	



ISO Test Sieves

**TECH NOTE!**

- ISO Test Sieves are available with opening sizes up to 125mm (5in). Please inquire for openings larger than 63mm.
- ISO Test Sieves are fitted with black rubber O-Rings.
- Details for Sieve Verification Services can be found in a separate listing within this section.
- ISO Sieves with 200mm or 300mm frames do not stack with ASTM 8in (203mm) or 12in (305mm) sieves.
- ISO Sieve Cloth can be custom mounted in 8in (203mm) frames. These items are non-returnable when supplied as ordered.

9.6 Accessories

ACCESSORIES	
Description	Model
<p><b>Clean-N-Stor</b> accessories are handy, time-saving devices for emptying, cleaning and weighing functions associated with sieving operations. Inverting an 8in or 200mm sieve on the stainless steel funnel allows quick emptying and cleaning of contents into a receiving scoop or pan. A sieve stack can also be stored on top of the funnel. A scoop and soft-bristle cleaning brush are included with all models. The SSA-801 attaches to the top of the SS-8R case. SSA-802 is a stand-alone model that can be positioned directly over an electronic balance, so sieve fractions can be weighed as the sieve is being cleaned. OBA-15R is an adjustable-height Clean-N-Stor version designed to fit over taller balances.</p> <p style="text-align: right;">Clean-N-Stor Attachment for SS-8R Stand-Alone Clean-N-Stor Adjustable-Height Clean-N-Stor</p>	<p>SSA-801 SSA-802 OBA-15R</p>
<p><b>Sieve Storage Racks</b></p> <p>The SSA-820 Wall-Mount Sieve Rack is designed for wall-mounted storage of 8in (203mm) diameter sieves. Sieves are held on edge in eleven individual 3in (76mm) wide compartments, each holding one full-height or two half-height sieves. Compartment bottoms are neoprene lined and inclined to keep sieves in place. Construction is all stainless steel. Holes are provided for mounting on 16in (406mm) centers and for bolting racks together vertically and/or horizontally. Rack construction is all stainless steel with rubber feet for optional desk or counter top use. The bottom front flange has a 1-1/4in (32mm) high area to label slots for sieve sizes. Overall Assembled Dimensions: 34-1/4x9x11in (870x229x279mm), WxDxH. Est. Ship Wt.: 26lb (12kg). The SSA-822 Adjustable Wall-Mount Sieve Rack for 12in (305mm) diameter sieves is similar in design to SSA-820, but has slots every 1/2in (13mm) for variable placement of the eight supplied dividers. Capacity is eight full-height or fourteen half-height sieves. Additional dividers are available in sets of five as SSA-823. Overall Assembled Dimensions: 36-1/4x13x15-3/4in (921x330x400mm), WxDxH. Sieve Rack Units are shipped with instructions for simple user assembly. Est. Ship Wt.: 40lb (18kg). The SSA-803 Adjustable Bench Sieve Rack holds all diameters of sieves up to 12in (305mm). This rack eliminates clutter and inconvenience of nested storage and facilitates easy retrieval of sieves for speed and efficiency in the lab. Stainless steel rack has non-skid rubber feet, and is supplied with two permanent and two adjustable rubber-coated sieve support rods. Unit accommodates twenty full-height (forty half-height) 8in sieves, twelve full-height (twenty four half-height) 12in sieves, or forty full-height 3in sieves. Sizes may also be mixed, and be as small as 3in diameter. Optional SSA-804 Support Rod Set contains two rubber-covered rods, and may be used to increase the capacity for 3in full-height sieves to eighty. Dimensions: 26x13x13in (660x330x330mm), WxDxH. Est. Ship Wt.: 8lb (4kg).</p> <p style="text-align: right;">Wall-Mount Sieve Rack Adjustable Wall-Mount Sieve Rack Adjustable Bench Sieve Rack</p>	<p>SSA-820 SSA-822 SSA-803</p>
<p><b>Small Fine Sieve Cleaning Brush</b> has soft, 100% China bristles in round 3/4in (19mm) ferrule that are tapered for use with fine mesh sieves. Especially handy for 3in diameter or Precision Electroformed sieves and others of small diameter. Overall length is 5in (127mm) with wood handle.</p>	<p>TSA-168</p>
<p><b>Fine Sieve Cleaning Brush</b> is ideal for cleaning No.16 and finer sieves. Soft bristle, nicked steel ferrule, lacquered wood handle, 1-1/4in diameter and 5-3/4in long.</p>	<p>TSA-170</p>
<p><b>Coarse Sieve Cleaning Brush</b> has an 8-1/2in curved plastic handle with 1-1/2in x 1-3/4in of slanted brass wire bristles—perfect for No.30 and coarser wire cloth in round sieves.</p>	<p>TSA-172</p>



SSA-802 shown with Sieve



TSA-168



TSA-170



TSA-172



SSA-820 shown with Sieves

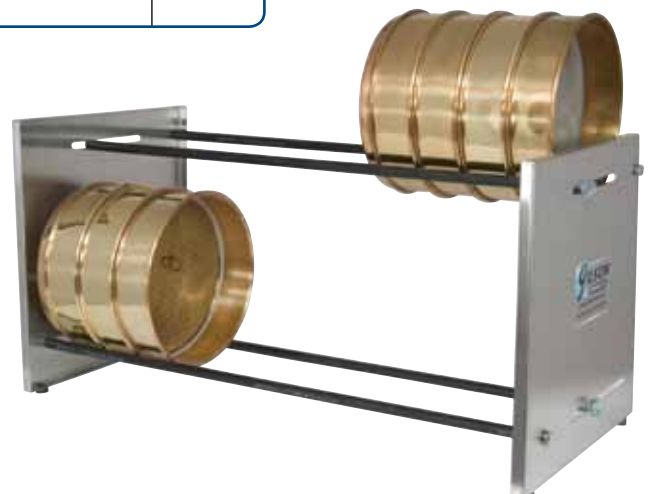

SSA-803 shown with 8in full-height Sieves